



Call for Artists

Downtown Hayward Calls for Art Submissions for Graphic Wrapping of Downtown Receptacles

The Downtown Hayward Improvement Association (DHIA) is a local nonprofit organization that is tasked with the daily maintenance, beautification and promotion of the City of Hayward's central business district. Our Association has recently created a new public art program in collaboration with our City partners to beautify our downtown district with artwork from local creators!

Our partners at the City of Hayward and Big Belly have enlisted our help to find local artists or artist teams to submit several unique designs to be selected, printed, and displayed on big belly receptacle stations recently placed in Downtown Hayward. The DHIA is calling for artists to submit their designs for potential display within our downtown community for a full calendar year! The selected artists and/or artist teams will be compensated for their submitted artwork and links will be embedded on the receptacles that will direct visitors back to the Downtown Hayward website for more details on the artwork, artist profile, and overall public art program.

In total there are thirty-five (35) dual-set Big Belly receptacles installed throughout the downtown district. The DHIA is seeking artist submissions to graphically wrap all thirty-five (35) receptacle sets in selected artwork. There is no limit on the number of submissions an artist can enter for this program. Multiple designs from the same artist(s) may be selected. The design themes should be centered around the history & heritage of Hayward, the artistic and creative environment of the City, and the contemporary culture of its citizenry.

The DHIA's District Identity & Streetscape Improvement (DISI) Committee will review all artist submissions and select artwork based on the design theme described in the criteria below. The selected artists will each receive \$800.00 (per design) for their final artwork to be placed on multiple units (at least one) for an approximate one (1) year term.

If you're interested in submitted designs to this program, please follow the instructions below for how to submit artwork for consideration:

- Commission an artistic display according to the *positive* themes of: history & heritage of Hayward, the artistic and creative environment of the City, the contemporary culture of its citizenry, local landscapes and scenic overlooks,

DOWNTOWN HAYWARD IMPROVEMENT ASSOCIATION

22654 Main Street • Hayward, CA 94541

symbolic landmarks, historical figures or positive symbols reflecting the diverse and unique experiences of Hayward. Submissions that emphasize or relate to downtown will be

- Submitted artwork adheres to the dimensions provided in this packet for the Big Belly units. Submissions that do not conform to these dimensions may be disqualified.
- Will accept submissions from individual artists or artist team and/or collectives. Artists, teams, collectives, etc. can be based anywhere, however, we will prioritize Bay Area individuals and collectives should all criteria and work be measured equally.
- If selected, DHIA staff will work with you on specifications for the finished design to be reproduced and printed according to the pre-approved dimensions.
- For some background on the district and up-to-date images and news visit: <https://www.instagram.com/downtownhayward/>
- Please submit a sketch of the proposed artwork, including what colors, themes, images, iconography, etc. with the attached application to the email listed below.
- Please include your full contact information, including phone, email, address, and website or artistic medium of choice (Instagram, Wordpress, etc.)
- Feel free to submit additional information such as your bio, samples of your work, anything that you believe reflects your creative portfolio.
- **Proposals must be submitted by: November 15th, 2024 at 5:00 PM**

To submit your application electronically, please use the following:

info@downtownhayward.com

Subject Line: Big Belly Artwork Submission

DOWNTOWN HAYWARD IMPROVEMENT ASSOCIATION

22654 Main Street • Hayward, CA 94541

Current (real world) examples of Big Belly receptacle stations in Downtown Hayward that will host selected artwork:



Current examples of Big Belly receptacles adorned with professional/community artwork in other business district in and around the San Francisco Bay Area.



Questions? Please email Dominic Li Mandri at info@downtownhayward.com

DOWNTOWN HAYWARD IMPROVEMENT ASSOCIATION

22654 Main Street • Hayward, CA 94541

Bigbelly Artist Application

Name of Artist or Group:	
Primary Contact Name/Title (if the applicant is an organization or group):	
Address:	
Primary Contact Telephone:	Primary Contact Email:
Digital Portfolio URL:	
Please explain your overall design concept (you may use rough drawings if needed):	

Bigbelly smart Waste & Recycling System

Wrap Decal Specifications

HC5 and SC5: Art Submission Requirements

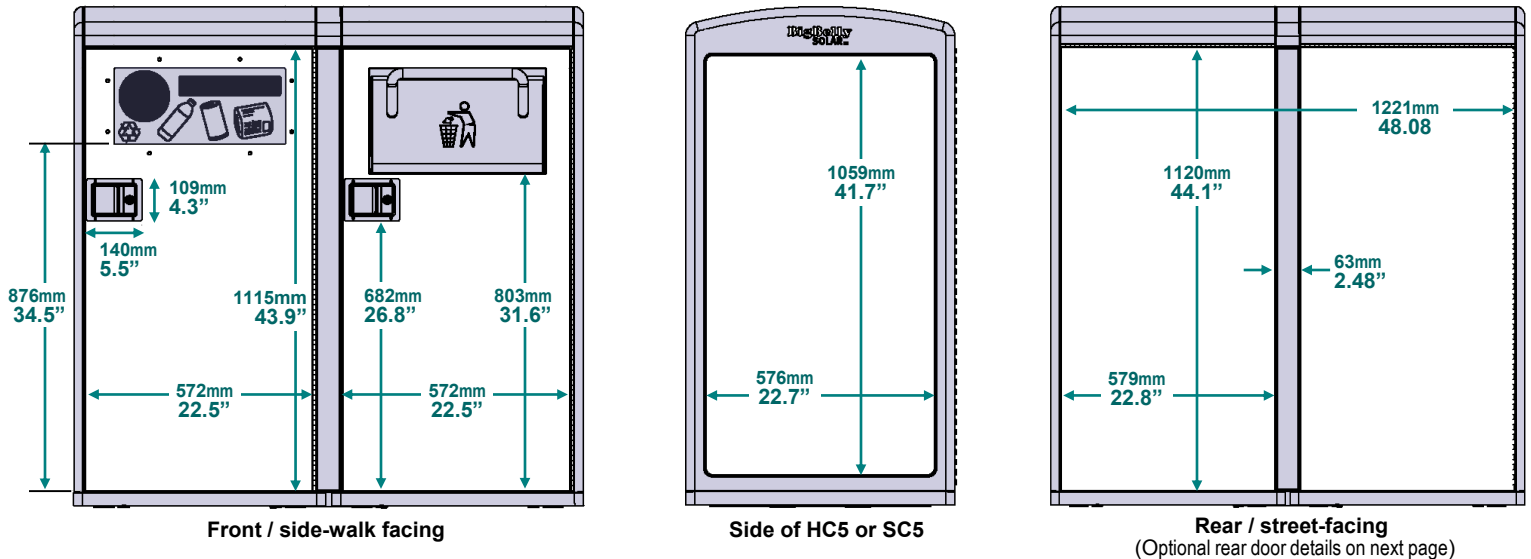

NOTE: We do not recommend applying decals to the shaded areas above (HC5 hopper or curved edges of side panels). Decal-appropriate areas are shown in white.

Acceptable PC and Mac file formats

- ▶ EPS of any type including Illustrator and Photoshop
- ▶ AI - Adobe Illustrator
- ▶ PSD - Photoshop, any format
- ▶ PDF - Adobe Acrobat
- ▶ TIFF - Tagged Image File Format

Image and font requirements

- ▶ Include all images that have been placed or imported into the final layout of your file. These image files are important to the quality of your final print.
- ▶ If you use a font other than a standard MS Word font, be sure to include all fonts used in your artwork whenever possible, otherwise send all fonts converted to outlines/curves/line art.
- ▶ Placed or imported images should be no less than 100 dpi (dots per inch) at final output size.

How to submit your files

- ▶ **Mail us a CD or DVD**—always include a hard copy printout to cross-check the hard copy against the electronic file.
- ▶ **Email or upload your files**—always include a PDF of what you want printed to cross-check the PDF against the electronic file.

To upload files, go to [HTTP://FASTSIGNS.FROM-OR.COM](http://FASTSIGNS.FROM-OR.COM)

2 inch bleed required

- ▶ An overall artwork bleed of 2 inches on all sides is required. Artwork that does not provide this bleed may not fit correctly.

Materials used

- ▶ 3M IJ-39-20 film
- ▶ Digital print using UV stable inks
- ▶ 3M 8509 Laminate

Color specifications

- ▶ Whenever possible send your files in "layers." If color corrections are required adjustments can be made as necessary.
- ▶ If you want specific color matches then PMS Pantone colors must be specified within the file as well as on your hard copy proof.
- ▶ Color swatches are an acceptable substitute to Pantone colors. We will match PMS colors as closely as possible.
- ▶ If colors are not specified then we will assume that color matching is not critical.

For further assistance

- ▶ Please contact Bigbelly Solar (888.820.0300) or Jeff Parsons at FASTSIGNS (844.300.1560).
- ▶ If you are in need of design services, contact Jeff Parsons at FASTSIGNS (Jeff.Parsons@fastsigns.com or 844.300.1560). Please note additional charges may apply for some design services.

Info_WrapSpecs(HC5-SC5)_2018Jun

Wrap Decal Specifications

HC5 and SC5: Front & Rear Door* Wrap Details

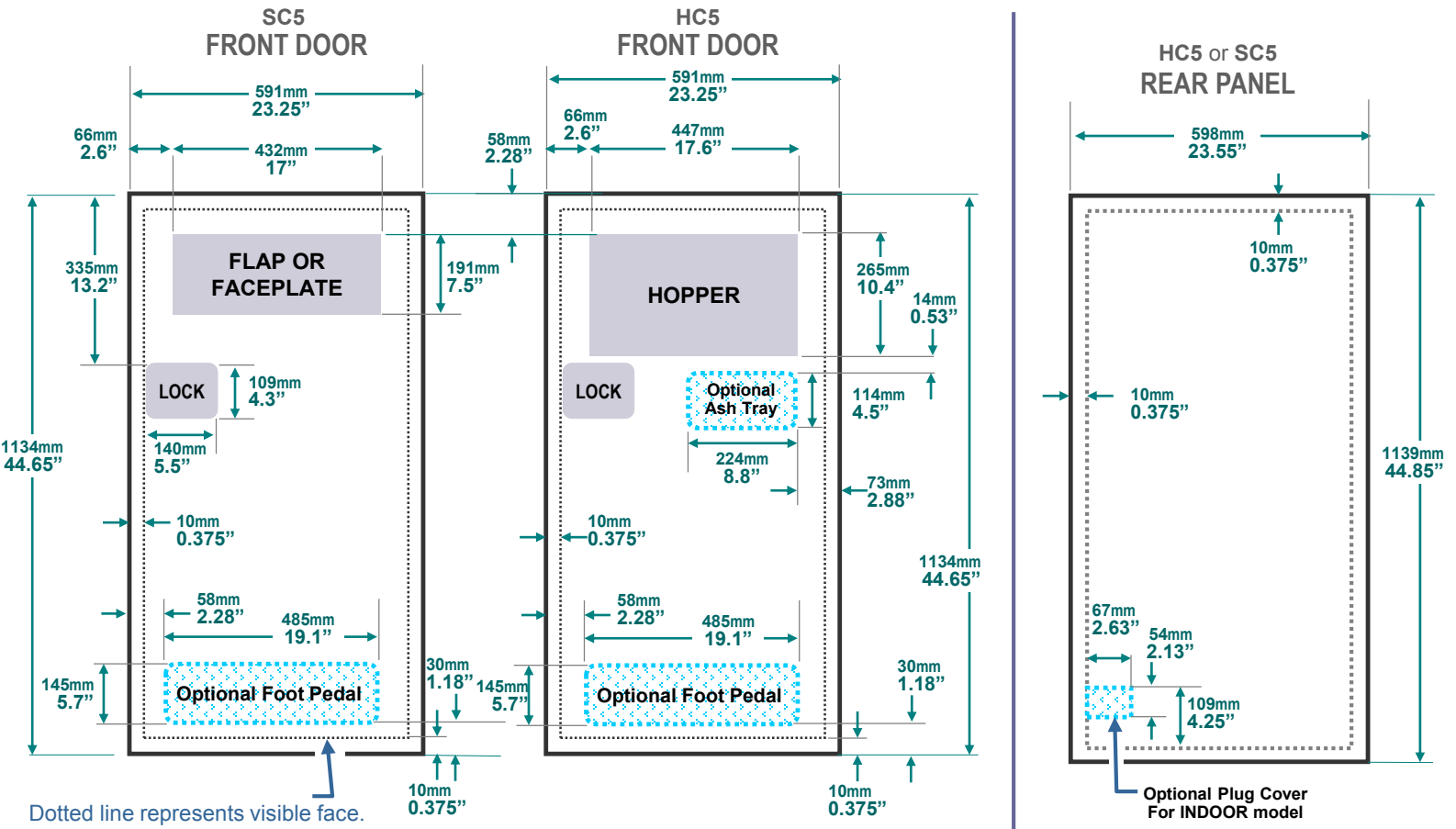

The overall dimensions include 3/8" (10mm) bleed on all four sides to allow wrapping around Door and Rear Panel.

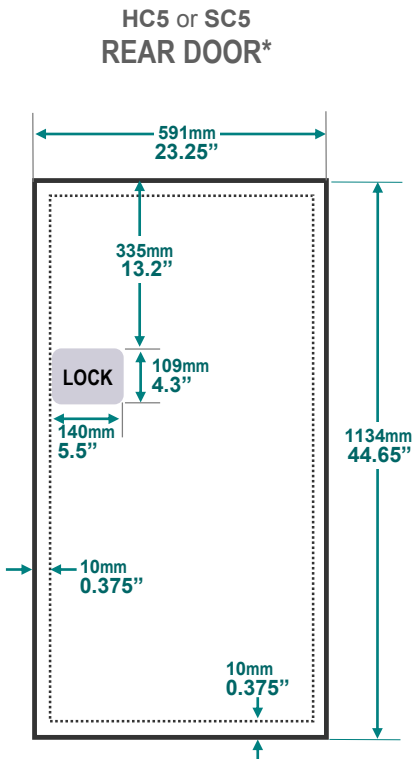

SC5: Faceplate Details

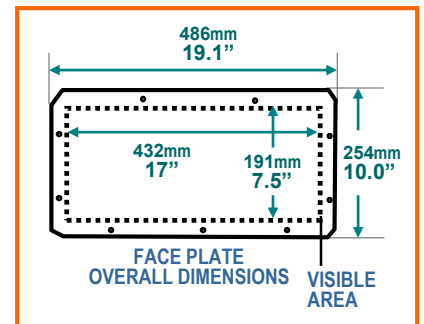
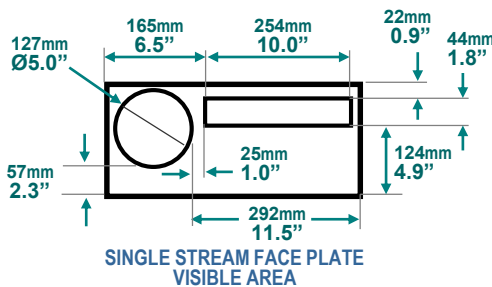
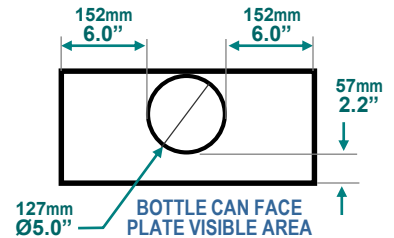
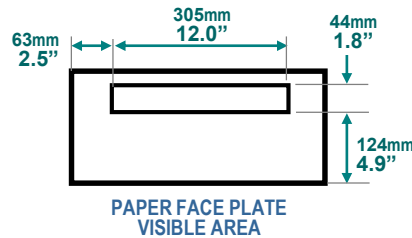

* No longer available. May exist on some stations before 9/2016.

Wrap Decal

Recommended Field Installation Procedure

Front Door or Rear Door*

- Center the wrap on the door.
- If there are protruding studs in the footplate area: Cut a slit between the two studs on either side of the foot pedal opening
- Installer should squeegee the wrap tightly around components (e.g. Hopper, lock) and carefully trim the wrap to avoid damaging the powder coat finish. [Fig 1]

 Make 'X' cuts for Door Locks, Hopper, Flap or Faceplate openings, Ashtray or Foot Pedal areas to ease installation.

- Installer must manually cut out notch in the corners to allow the extra 3/8" material to fold around the left and top sides of the door. [Fig 1]
- If there are protruding studs in the footplate area: Cut a 0.5" x 4.5" rectangle around the studs to remove extra material. [Fig 2]
- Fold the excess material over the edges of the Door. The Front Door Key will be needed to gain access to these surfaces. Corners should be cleanly aligned with no gaps or exposed areas.
- Installer must manually trim away excess material on the door along the hinge and bottom edge. [Fig 1]

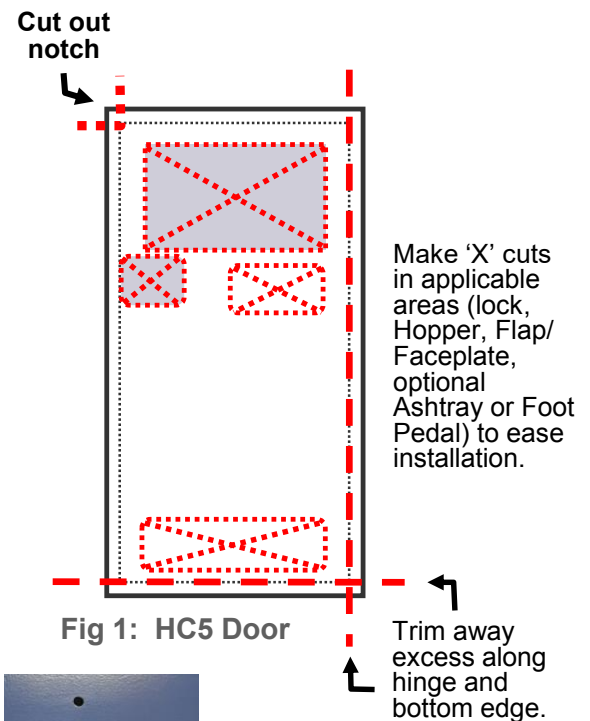



Fig 1: HC5 Door



Fig 2: Foot Pedal Wrap Cutout

Rear Panel

- Center the wrap on the Rear Panel.
 - Installer must manually cut away excess material along all 4 edges. [Fig 4]
-  Use caution when cutting/trimming the wrap to prevent damage to the powder coat finish.
- Installer must also trim 0.5" radii in the corners to discourage finger picking. [Fig 3]

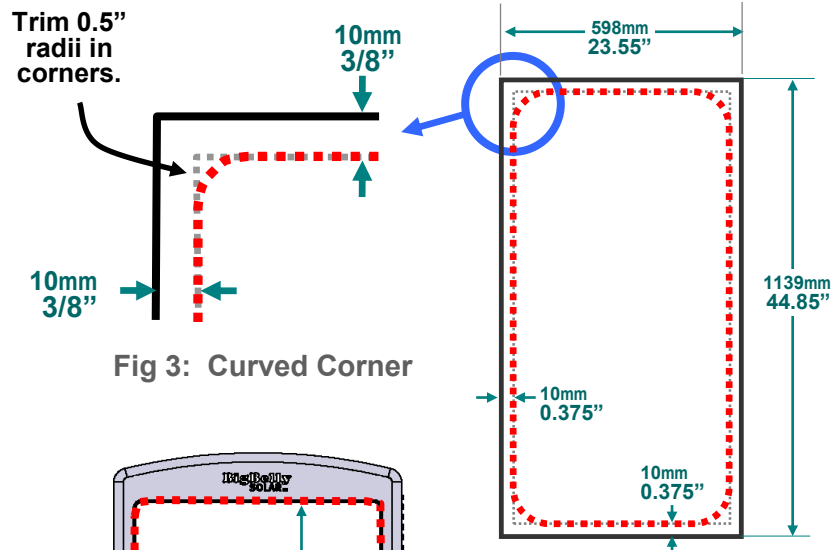
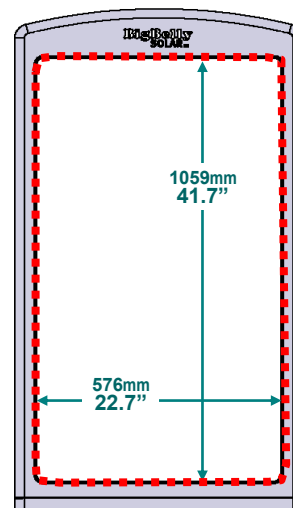

Fig 3: Curved Corner

HC5 or SC5
Fig 4: Rear Panel

Side-Skin

- Prepare surface to remove dirt and oils.
- Use a foam brush to apply a 1-2" (25.4-50.5mm) border of 3M Primer 94 where the graphic will be applied.
- Wait for the Primer to dry then center and place graphic on Side-Skin.
- Trim off all four corners of the graphic only 5mm in from the edge.
- Pull back the backing of the graphic on one side a few inches in and trim off along the inset of the Side-Skin.
- Attach exposed tack to Side-Skin. Then attach remainder with squeegee.
- With a heat gun and a rubber roller, heat the border where the primer was applied, and roll onto the Side-Skin where heated. Do this until the border and corners are all attached.



HC5 or SC5
Fig 5: Side-Skin

* The optional Rear Doors are no longer available. They may exist on some stations before 9/2016.